

Crew fixed with barslides

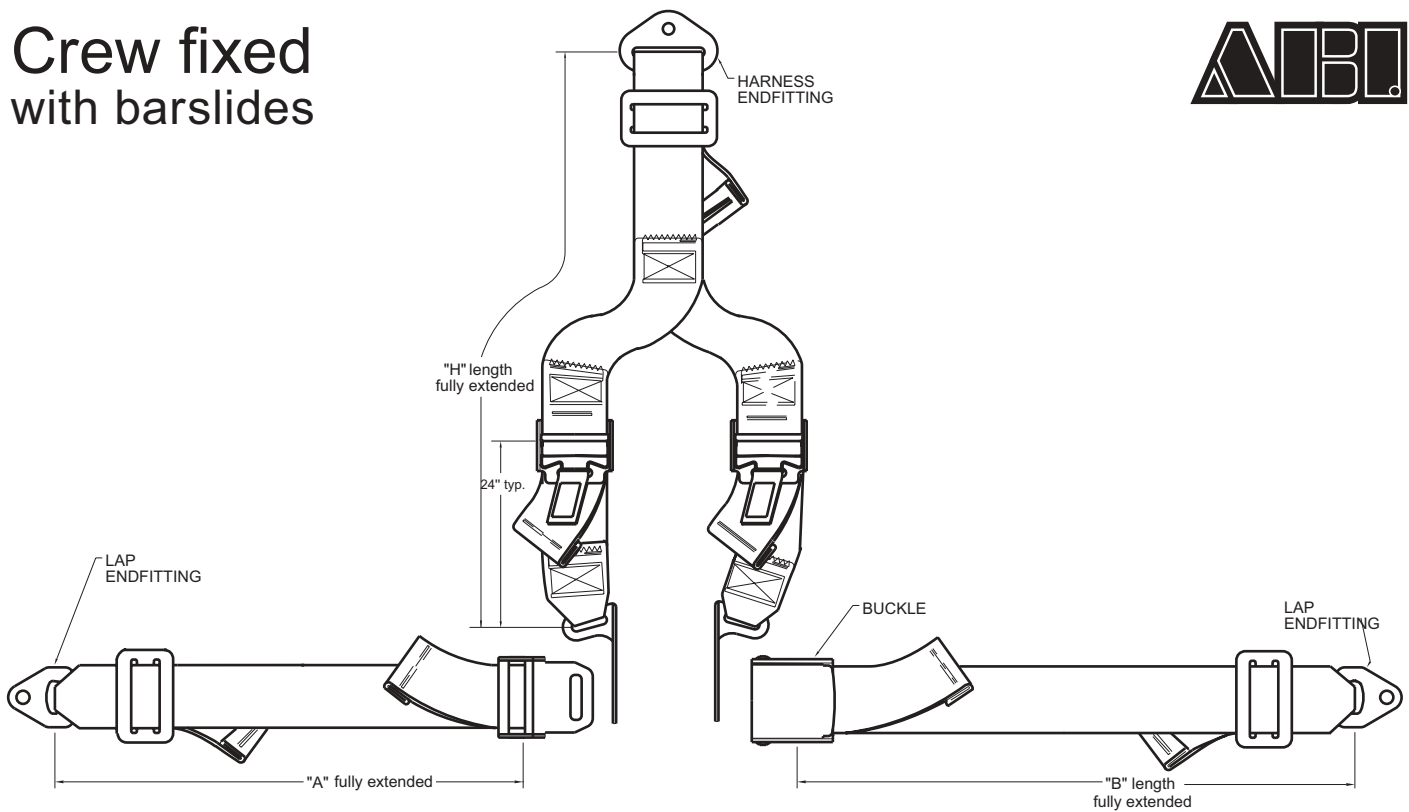

PART NO.

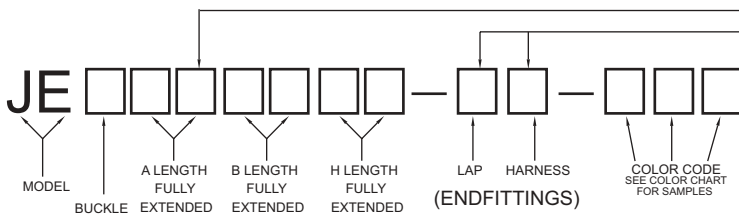

SAMPLE PART

J E A 2 6 2 8 5 4 - B C - 0 1 2

The 4-point fixed harness belt assembly is used primarily as a crew restraint. The lift lever buckle is a standard in the general and commercial aviation markets. Please check the Reel Selection Page in this catalog to find the proper reel.

The ABISS line is made of stainless steel to prevent rust and corrosion. Custom plating as well as engraving can be performed easily. The difference between a JE and a JD is that an

| BUCKLE CODES | | |
|--------------|-----|----------------|
| CODE | P/N | DESCRIPTION |
| A | 1A | 35° ALUM. LIFT |
| B | 1B | 35° S.S. LIFT |
| E | 1E | 90° ALUM. LIFT |
| F | 1F | 90° S.S. LIFT |

ENDFITTINGS

| | | |
|----|----|----|
| | | |
| 4A | 4B | 4C |
| | | |
| 4D | 4E | 4G |

ENDFITTING CODES

| CODE | P/N | BOLT HOLE | CODE | P/N | BOLT HOLE |
|------|-----|-----------|------|-----|-----------|
| A | 4A | .375 HOOK | D | 4D | .386 HOLE |
| B | 4B | .25 HOLE | E | 4E | .406 HOLE |
| C | 4C | .325 HOLE | G | 4G | .386 HOLE |

NOTES:

- STANDARD BUCKLE IS ANODIZED ALUMINUM AND STAINLESS STEEL; PLATED METAL FINISHES AVAILABLE.
- RESTRAINT ASSEMBLIES CONFORM TO FAA TSO C114.
- IDENTIFICATION LABELS AFFIXED TO EACH HALF OF ASSEMBLY.
- LAP ASSEMBLY RATED TO 3000 lbs, HARNESS ASSEMBLY RATED TO 2500 lbs.

Aircraft Belts, Inc.

1176 Telecom Drive

Creedmoor, NC 27522

Phone: 800.847.5651 - Fax 919.956.4220

www.aircraftbelts.com