

Standard Lap w/barslides

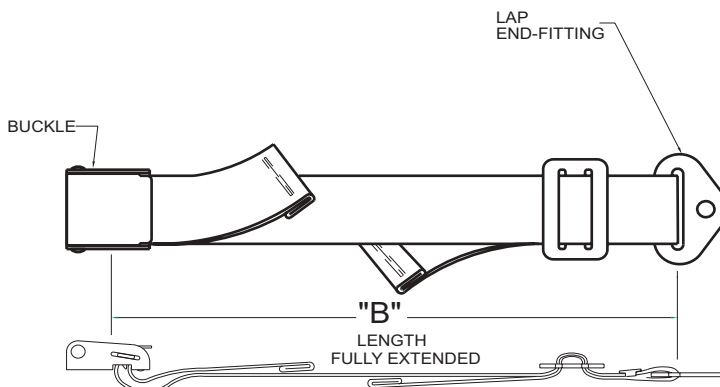

PART NO.

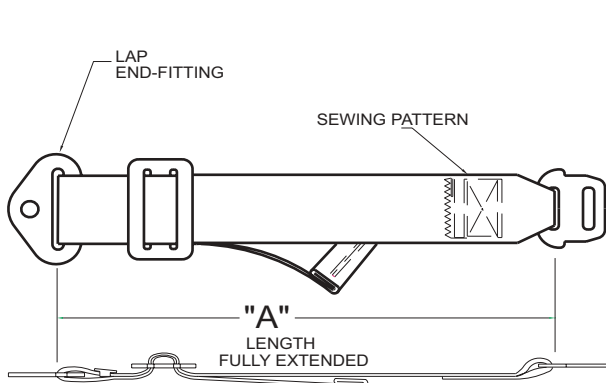

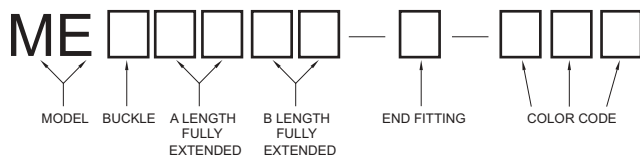





SAMPLE PART
M E E 2 6 2 8 - E - 0 1 0

This versatile restraint is widely used for passenger seats. The lift lever configuration is a standard in the general and commercial aviation markets.

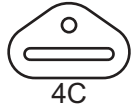
The ABISS line is made of stainless steel to prevent rust and corrosion. Custom plating as well as engraving can be performed easily. The difference between the MD and the ME are the barslides on the ME.

BUCKLE CODES		
CODE	P/N	DESCRIPTION
A	1A	35° ALUM. LIFT
B	1B	35° S.S. LIFT
E	1E	90° ALUM. LIFT
F	1F	90° S.S. LIFT

ENDFITTINGS		
 4A	 4B	 4C
 4D	 4E	 4G

ENDFITTING CODES					
CODE	P/N	BOLT HOLE	CODE	P/N	BOLT HOLE
A	4A	.375 HOOK	D	4D	.386 HOLE
B	4B	.25 HOLE	E	4E	.406 HOLE
C	4C	.325 HOLE	G	4G	.386 HOLE

Aircraft Belts, Inc.
1176 Telecom Drive
Creedmoor, NC 27522
Phone: 800.847.5651 - Fax 919.956.4220
www.aircraftbelts.com

- NOTES:
 1. STANDARD BUCKLE IS ANODIZED ALUMINUM AND STAINLESS STEEL; PLATED METAL FINISHES AVAILABLE
 2. SEAT BELT ASSEMBLIES CONFORM TO FAA TSO C22(g).
 3. IDENTIFICATION LABELS AFFIXED TO EACH PART ON LAP.
 4. LAP ASSEMBLY RATED TO 3000 lbs.