

# 5-point Rotary automatic with barslides

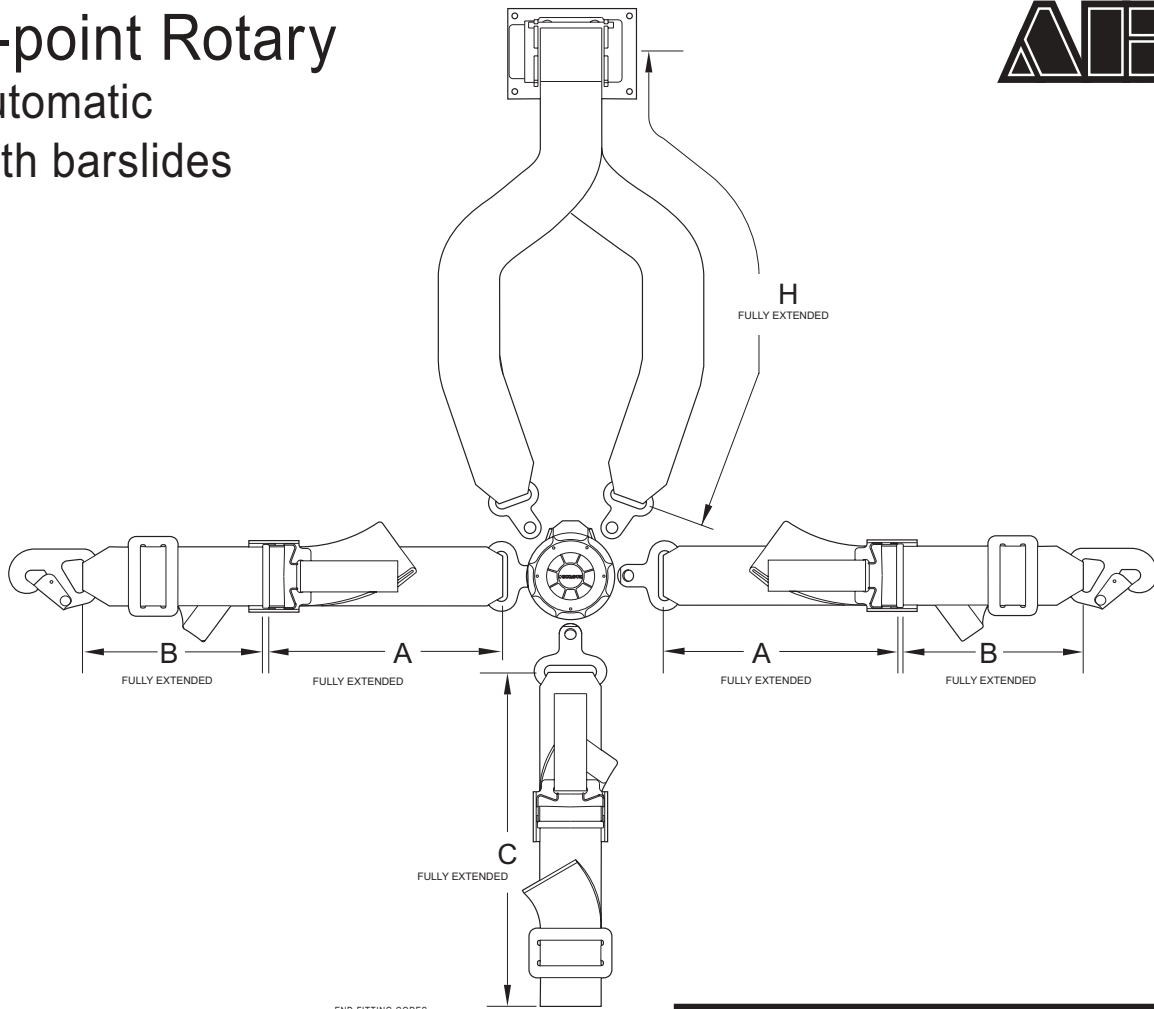

## PART NO. SYSTEM

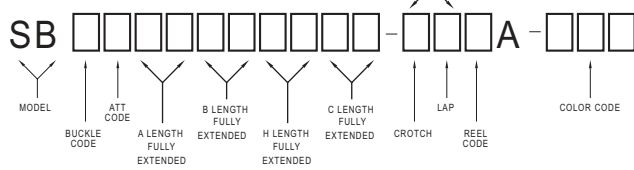

## SAMPLE PART

SBAB26304612-BEEA-601

The cam lock rotary is available in a 5-point or 4-point configuration. Dual shoulder harness attachments and an optional anti-sub or crotch strap ensure a proper fit for your requirements. Please check the reel selection page in this section to find proper reel for your application.

The standard rotary buckle is made out of black polycarbonate, but an aluminum version is available for custom plating. The difference between the SA and SB is an installation adjuster is present on the SB.

BUCKLE CODES		PERM. BUCKLE ATTACHMENT	
CODE	P/N	CODE	DESCRIPTION
A	SL 10	B	LEFT
C	SL 11	C	RIGHT

ENDFITTINGS					
4D		4E		4G	
4C		4B		4A	
ENDFITTING CODES					
CODE	P/N	BOLT HOLE	CODE	P/N	BOLT HOLE
A	4A	.375 HOOK	D	4D	.386 HOLE
B	4B	.25 HOLE	E	4E	.406 HOLE
C	4C	.325 HOLE	G	4G	.386 HOLE

**Aircraft Belts, Inc.**  
**1176 Telecom Drive**  
**Creedmoor, NC 27522**  
**Phone: 800.847.5651 - Fax 919.956.4220**  
[www.aircraftbelts.com](http://www.aircraftbelts.com)

1. Complete assembly conforms to FAA TSO C114  
 2. Identification labels affixed to each portion of the assembly.  
 3. Lap assembly rated to 3000 lbs. Harness assembly rated to 2500 lbs.  
 4. Rotary buckle is black polycarbonate, but an aluminum version is available for custom plating