

5-Pt. Rotary Automatic

with harness adjusters and barslides

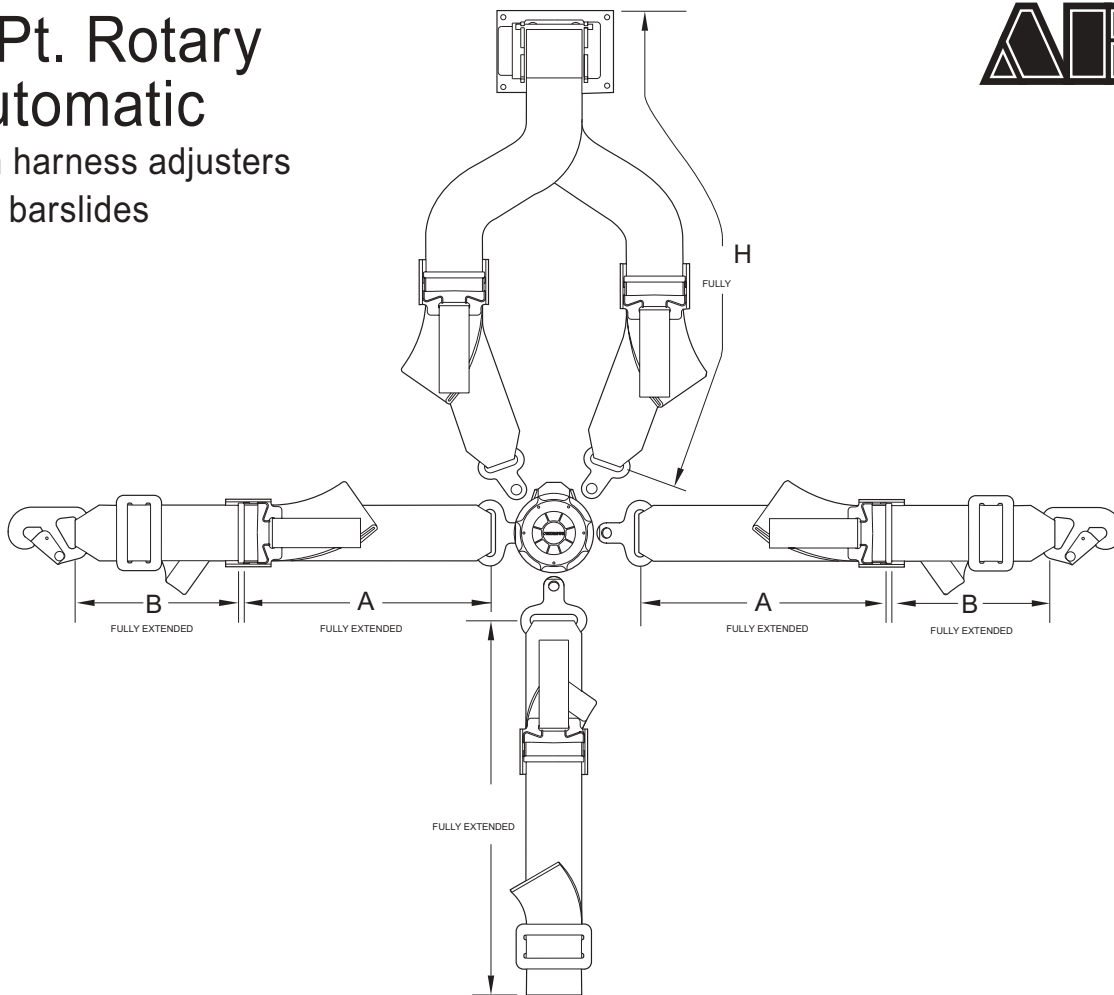

PART NO. SYSTEM

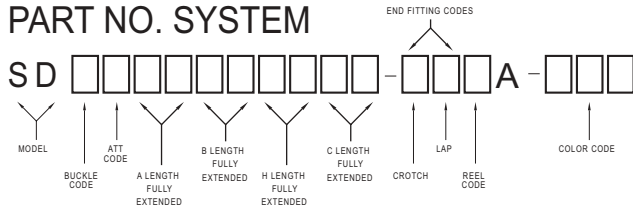

SAMPLE PART

SDAB26304612-BEEA-601

The cam lock rotary is available in a 5-point or 4-point configuration. Dual shoulder harness attachments and an optional anti-sub or crotch strap ensure a proper fit for your requirements. Refer to Hardware Selection for the proper crotch strap. Please check the reel selection page in this catalog to find the proper reel.

The difference between the SC and SD is that bar slides are present on the SD.

BUCKLE CODES		PERM. BUCKLE ATTACHMENT	
CODE	P/N	CODE	DESCRIPTION
A	SL 10	B	LEFT
C	SL 11	C	RIGHT

ENDFITTINGS		
4D	4E	4G
4C	4B	4A

ENDFITTING CODES					
CODE	P/N	BOLT HOLE	CODE	P/N	BOLT HOLE
A	4A	.375 HOOK	D	4D	.386 HOLE
B	4B	.25 HOLE	E	4E	.406 HOLE
C	4C	.325 HOLE	G	4G	.386 HOLE

1. Complete assembly conforms to FAA TSO C114
2. Identification labels affixed to each portion of the assembly.
3. Lap assembly rated to 3000 lbs. Harness assembly rated to 2500 lbs.
4. Rotary buckle is black polycarbonate, but an aluminum version is available for custom plating

Aircraft Belts, Inc.
1176 Telecom Drive
Creedmoor, NC 27522
Phone: 800.847.5651 - Fax 919.956.4220
www.aircraftbelts.com