

# 5-Point Rotary

## Static

with barslides and harness adjusters

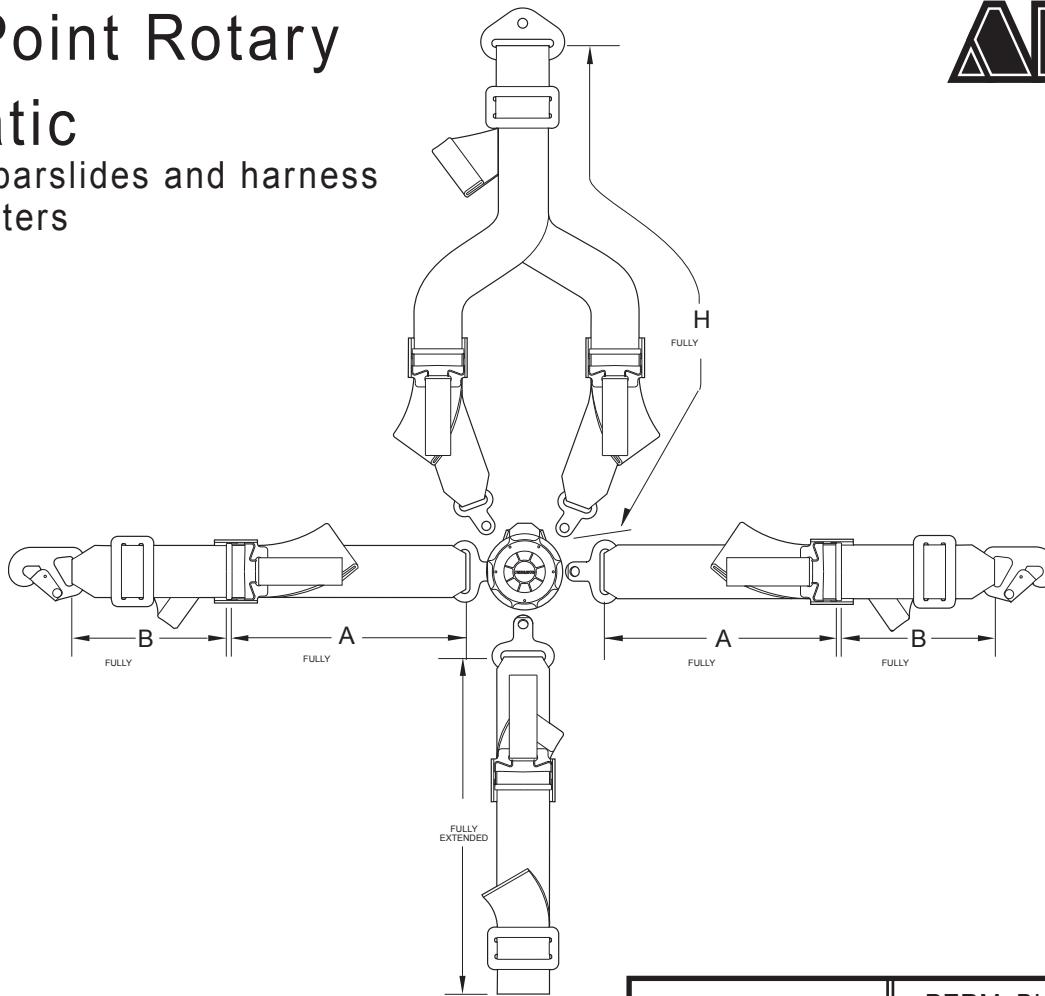

### PART NO. SYSTEM

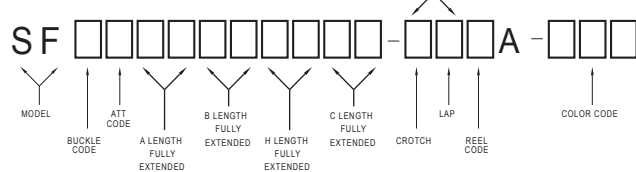

### SAMPLE PART

SFAB26304612-BEEA-601

The cam lock rotary is available in a 5-point or 4-point configuration. Dual shoulder harness attachments and an optional anti-sub or crotch strap ensure a proper fit for your requirements.

The standard rotary buckle is made out of black polycarbonate, but an aluminum version is available for custom plating. The difference between the SE and a SF is an installation adjuster is on the SF.

BUCKLE CODES		PERM. BUCKLE ATTACHMENT	
CODE	P/N	CODE	DESCRIPTION
A	SL 10	B	LEFT
C	SL 11	C	RIGHT

ENDFITTINGS					
4D		4E		4G	
4C		4B		4A	
ENDFITTING CODES					
CODE	P/N	BOLT HOLE	CODE	P/N	BOLT HOLE
A	4A	.375 HOOK	D	4D	.386 HOLE
B	4B	.25 HOLE	E	4E	.406 HOLE
C	4C	.325 HOLE	G	4G	.386 HOLE

1. Complete assembly conforms to FAA TSO C114
2. Identification labels affixed to each portion of the assembly.
3. Lap assembly rated to 3000 lbs. Harness assembly rated to 2500 lbs.
4. Rotary buckle is black polycarbonate, but an aluminum version is available for custom plating

**Aircraft Belts, Inc.**

**1176 Telecom Drive**

**Creedmoor, NC 27522**

**Phone: 800.847.5651 - Fax 919.956.4220**

[www.aircraftbelts.com](http://www.aircraftbelts.com)