

5-Point Rotary Dual Automatic

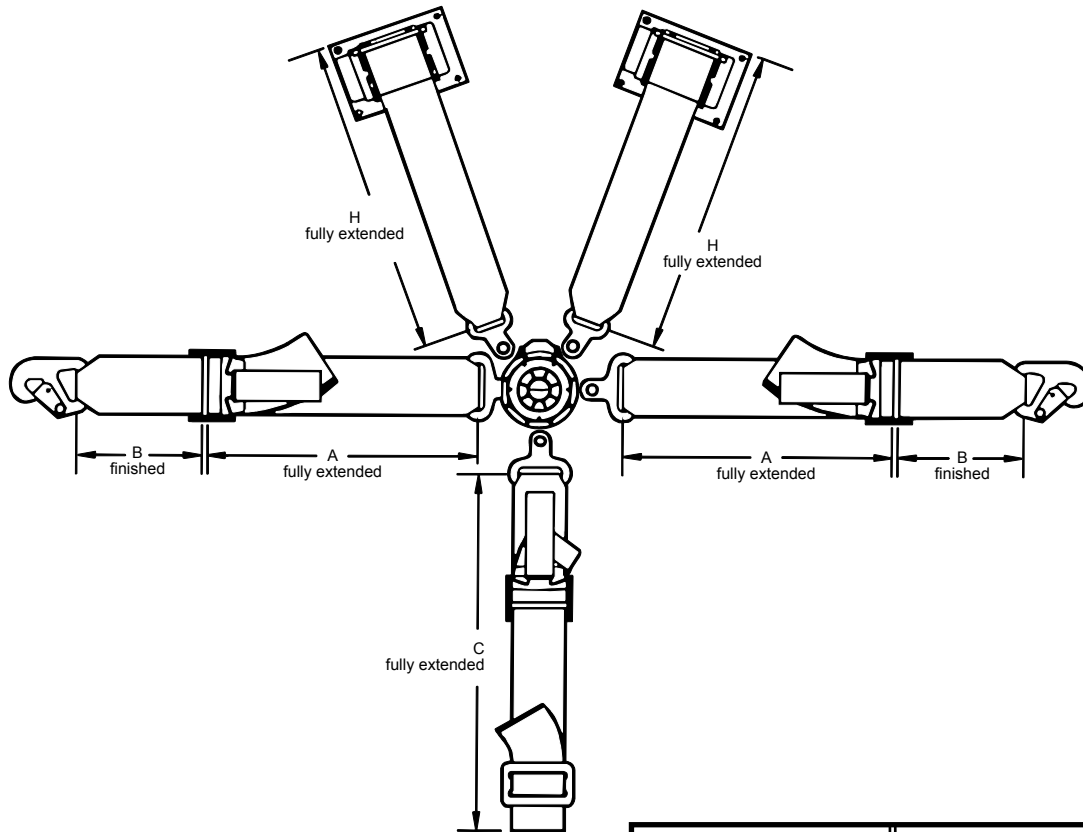

PART NO. SYSTEM

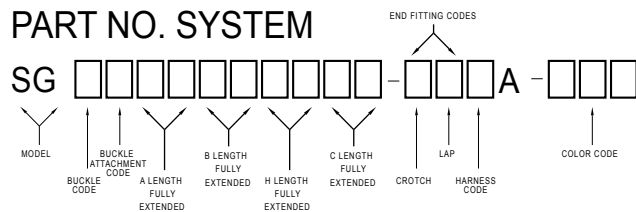

SAMPLE PART

SGAB26304612-BEEA-601

The cam lock rotary is available in a 5-point or 4-point configuration. Dual shoulder harness attachments and an optional anti-sub or crotch strap ensure a proper fit for your requirements. Refer to the hardware selection for the proper crotch strap.

Please make sure to check the reel selection

Aircraft Belts, Inc.

1176 Telecom Drive

Creedmoor, NC 27522

Phone: 800.847.5651 - Fax 919.956.4220

www.aircraftbelts.com

BUCKLE CODES		PERM. BUCKLE ATTACHMENT	
CODE	P/N	CODE	DESCRIPTION
A	SL 10	B	LEFT
C	SL 11	C	RIGHT

ENDFITTINGS		
4D	4E	4G
4C	4B	4A

ENDFITTING CODES					
CODE	P/N	BOLT HOLE	CODE	P/N	BOLT HOLE
A	4A	.375 HOOK	D	4D	.386 HOLE
B	4B	.25 HOLE	E	4E	.406 HOLE
C	4C	.325 HOLE	G	4G	.386 HOLE

Choose Reel Code from Hardware Selection

NOTES:

1. Complete assembly conforms to FAA TSO C114
2. Identification labels affixed to each portion of the assembly.
3. Lap assembly rated to 3000 lbs. Harness assembly rated to 2500 lbs.
4. Rotary buckle is black polycarbonate, but an aluminum version is available for custom plating