

5-Point Rotary Dual Static

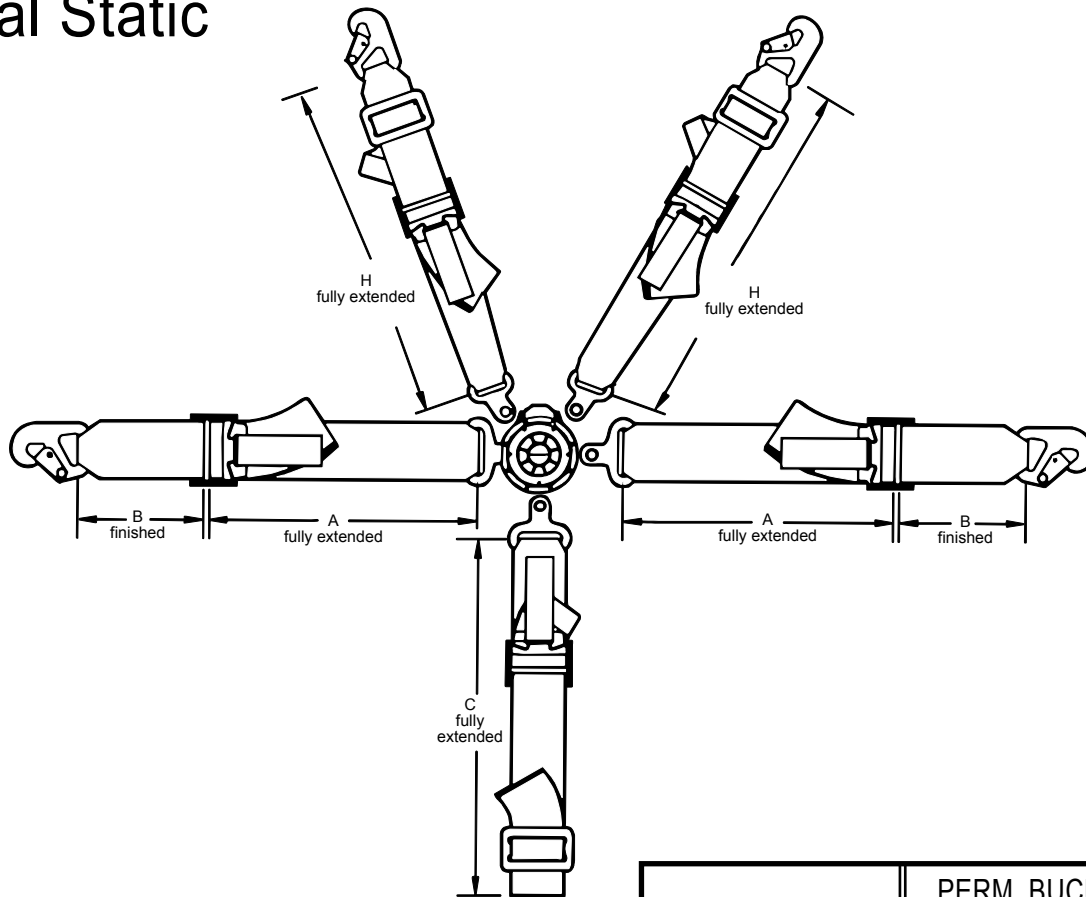

PART NO. SYSTEM

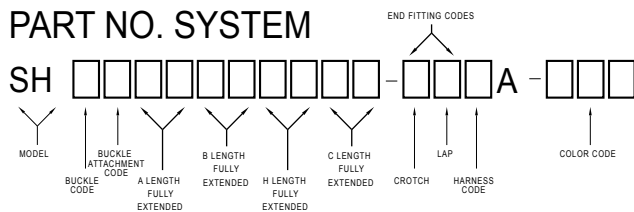

SAMPLE PART

SHAB26304612-BEEA-601

The cam lock rotary is available in a 5-point or 4-point configuration. Dual shoulder harness attachments and an optional anti-sub or crotch strap ensure a proper fit for your requirements. Refer to their Hardware Selection for the proper crotch strap.

BUCKLE CODES		PERM. BUCKLE ATTACHMENT	
CODE	P/N	CODE	DESCRIPTION
A	SL 10	B	LEFT
C	SL 11	C	RIGHT

END FITTINGS		
4D	4E	4G
4C	4B	4A

END FITTING CODES					
CODE	P/N	BOLT HOLE	CODE	P/N	BOLT HOLE
A	4A	.375 HOOK	D	4D	.386 HOLE
B	4B	.25 HOLE	E	4E	.406 HOLE
C	4C	.325 HOLE	G	4G	.386 HOLE

Aircraft Belts, Inc.

1176 Telecom Drive

Creedmoor, NC 27522

Phone: 800.847.5651 - Fax 919.956.4220

www.aircraftbelts.com

NOTES:

1. Complete assembly conforms to FAA TSO C114
2. Identification labels affixed to each portion of the assembly.
3. Lap assembly rated to 3000 lbs. Harness assembly rated to 2500 lbs.
4. Rotary buckle is black polycarbonate, but an aluminum version is available for custom plating