

3-point automatic

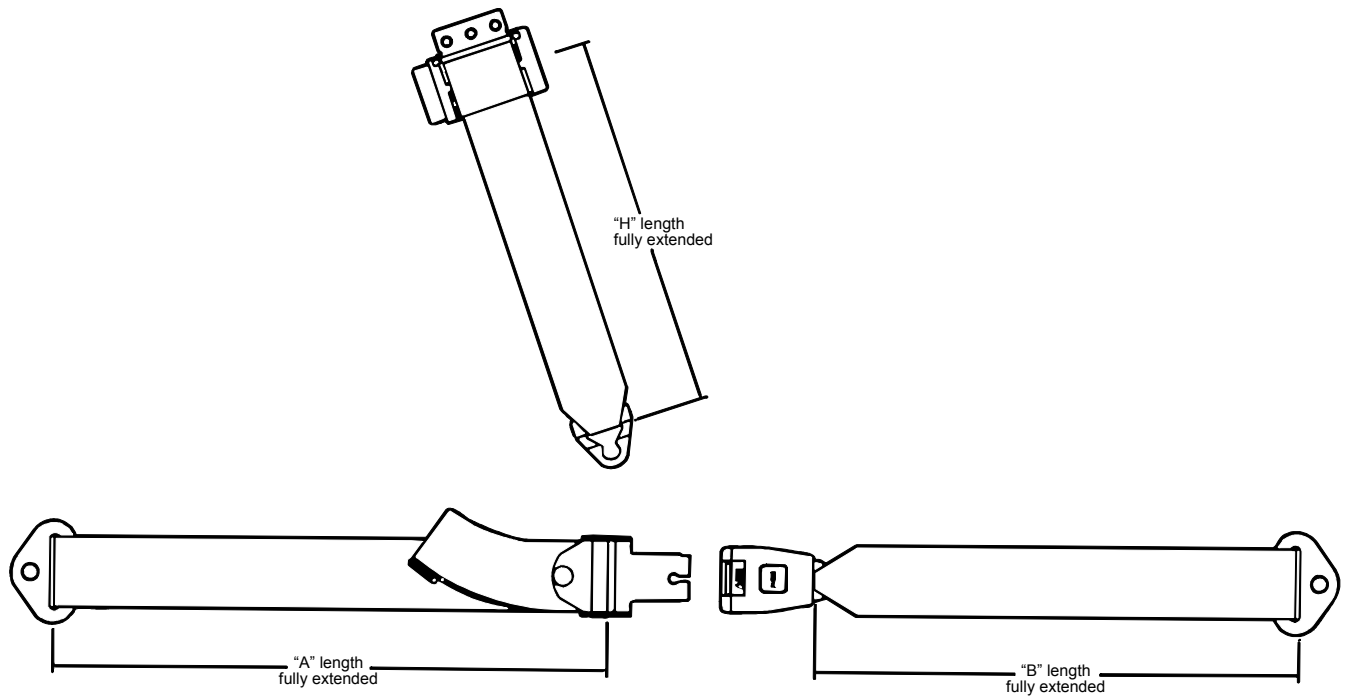

PART NO. SYSTEM

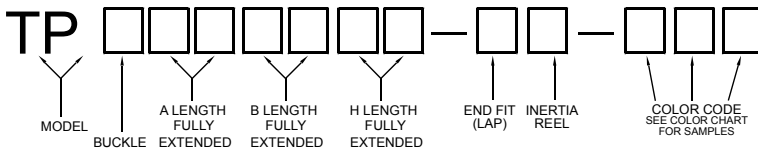

SAMPLE PART NO.

TPA262845 - EC - 012

The ABI Ultima can be used for any aviation application. Push button restraints have become especially popular in the business jet and general aviation marketplace. Please check the Reel Selection page in this catalog to find the proper reel.

A metal housing is available on this model to allow for decorative plating finishes. Contact ABI for additional information about this restraint system and available custom plating options.

Aircraft Belts, Inc.







1176 Telecom Drive

Creedmoor, NC 27522

Phone: 800.847.5651 - Fax 919.956.4220

www.aircraftbelts.com

BUCKLE CODES		
CODE	P/N	DESCRIPTION
A	3/87	2-way Buckle (metal housing)
B	3/87	2-way Buckle (plastic housing)
C	3/87	2-way Buckle (metal housing without top push button window)
D	3/87	Ultima 2-way Buckle (metal housing)
E	3/87	Ultima 2-way Buckle (plastic housing)

END FITTINGS		
 4A	 4B	 4C
 4D	 4E	 4G

END FITTING CODES					
CODE	P/N	BOLT HOLE	CODE	P/N	BOLT HOLE
A	4A	.375 HOOK	D	4D	.386 HOLE
B	4B	.25 HOLE	E	4E	.406 HOLE
C	4C	.325 HOLE	G	4G	.386 HOLE

Choose Reel Code from Hardware Selection

NOTES:
 1. STANDARD BUCKLE IS ANODIZED ALUMINUM AND STAINLESS STEEL; PLATED METAL FINISHES AVAILABLE.
 2. RESTRAINT ASSEMBLIES CONFORM TO FAA TSO C114.
 3. IDENTIFICATION LABELS AFFIXED TO EACH PART ON LAP.
 4. LAP ASSEMBLY RATED TO 3000 lbs., HARNESS ASSEMBLY RATED TO 2500 lbs.